

HUNTLEIGH

FD1/FD2/FD3

Anwendungshinweise

Kullanım Talimatları

Brugsvejledning

Instrucciones de uso

χρήσης

使用方

Mode d'emploi

Bruksanvisning

Gebruiksaanwijzing

aanwijzing

INSTRUCTIONS FOR USE

Bruksan

alimatları

使用方法

Käyttöohjeet

Instruções de Utilização

Istruzioni per l'uso

Anwendungshinweise

Οδηγίες χρήσης

Anwendungshinweise

HIGH SENSITIVITY POCKET DOPPLERS

Table of Contents

Doppler Measurement Sites and Recommended Probes3

1. Safety	4
1.1 <i>Warnings</i>	4
1.2 <i>Patient Applied Parts</i>	5
2. Introduction	6
2.1 <i>Unpacking / Preliminary Checks</i>	6
2.2 <i>Battery Insertion / Relacement</i>	6
2.3 <i>Product Controls</i>	7
2.4 <i>Product Labelling</i>	7
3. Operation	9
3.1 <i>Vascular Mode (FD2 Only)</i>	9
3.2 <i>Obstetric Mode</i>	10
3.3 <i>After Use</i>	12
4. Care and Cleaning	13
4.1 <i>General Care</i>	13
4.2 <i>General Cleaning and Disinfecting</i>	14
4.3 <i>Cleaning and Disinfecting Patient Applied Parts</i>	14
4.4 <i>Maintenance and Repair</i>	15
5. Specifications	16
5.1 <i>Equipment Classification</i>	16
5.2 <i>Standards Compliance</i>	16
5.3 <i>FHR Performance</i>	16
5.4 <i>General</i>	17
5.5 <i>Environmental</i>	17
6. End of Life Disposal.....	18
7. Warranty & Service	19

Dopplex, and Huntleigh are registered trademarks of Huntleigh Technology Ltd.
2004.

Doppler Measurement Sites and Recommended Probes

1 Jugular Vein
VP4HS, VP5HS

2 Subclavian Vein
VP4HS, VP5HS

3 Fetus
OP2HS, OP3HS

4 Femoral Vein
VP4HS, VP5HS

5 Great Saphenous Vein
VP5HS, VP8HS, EZ8

6 Small Saphenous Vein
VP8HS, EZ8

7 Posterior Tibial Vein
VP8HS, VP10HS, EZ8

8 Posterior Tibial Artery
VP8HS, EZ8

9 Vertebral Artery
VP4HS, VP5HS

10 Carotid Artery
VP5HS, VP8HS, EZ8

11 Subclavian Artery
VP4HS, VP5HS

12 Brachial Artery
VP8HS, EZ8

13 Ulnar Artery
VP8HS, EZ8

14 Radial Artery
VP8HS, EZ8

15 Femoral Artery
VP4HS, VP5HS

16 Digital Artery
VP8HS, VP10HS, EZ8

17 Penis
VP10HS, EZ8

18 Popliteal Artery
VP5HS

19 Metatarsal Artery
VP8HS, VP10HS, EZ8

20 Dorsalis Pedis Artery
VP8HS, VP10HS, EZ8

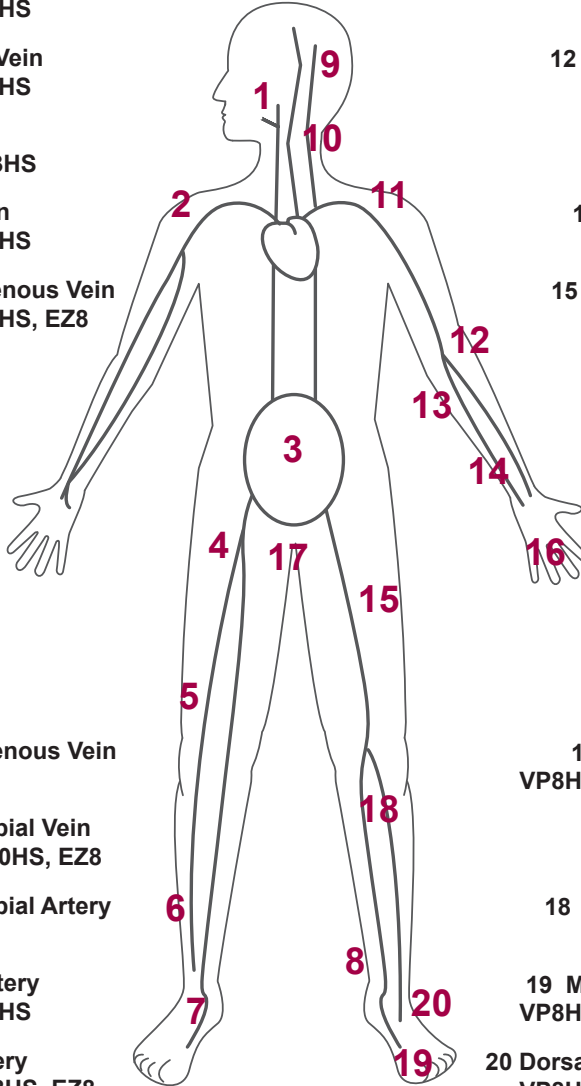

1. Safety



Before using this equipment, please study this manual carefully and familiarise yourself with the controls, display features and operation. Ensure that each user fully understands the safety and operation of the unit, as mis-use may cause harm to the user or patient, or damage to the product.



We recommend that exposure to ultrasound should be kept As Low As Reasonably Achievable - (ALARA guidelines). This is considered to be good practice and should be observed at all times.

Please keep these Instructions for Use to hand for future reference.



Attention, consult this manual. Refer to safety section.



Attention, consult accompanying documents / Instructions for Use

1.1 Warnings



Do not use in the presence of flammable gases such as anaesthetic agents



Do not use in the sterile field unless additional barrier precautions are taken.



Do Not :

- *immerse in any liquid, (except FD1/FD3 probe)*
 - *use solvent cleaner,*
 - *use high temperature sterilising processes (such as autoclaving),*
 - *use E-beam or gamma radiation sterilisation.*
-



The main unit is not waterproof and must not be immersed. For underwater use where contamination or cross-infection may occur, additional barrier precautions must be taken.



Do not use on the eye.



Do not dispose of batteries in fire as this can cause them to explode.



Do not attempt to recharge normal dry-cell batteries. They may leak, cause a fire or even explode.



This product contains sensitive electronics, therefore, strong radio frequency fields could possibly interfere with it. This will be indicated by unusual sounds from the loudspeaker. We recommend that the source of interference is identified and eliminated



Any equipment connected to RS232 interface must be compliant with IEC60601-1:2005.



Connect headphones only to the headphone socket.



Dopplex Dopplers are screening tools to aid the healthcare professional and should not be used in place of normal vascular or fetal monitoring. If there is doubt as to vascularity or fetal well-being after using the unit, further investigations should be undertaken immediately using alternative techniques.

1.2 Patient Applied Parts

As defined in IEC60601-1:2005, the patient applied parts of the Dopplex Dopplers are the ultrasound probes.

2. Introduction

2.1 Unpacking / Preliminary Checks

Contents

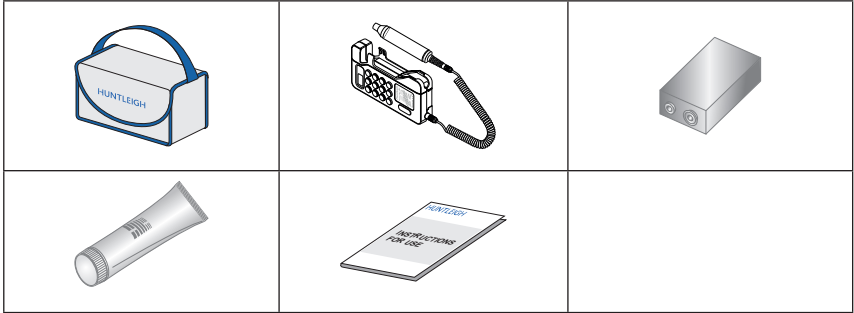

Delivery Inspection

Huntleigh takes every precaution to ensure that goods reach you in perfect condition. However, accidental damage can occur in transit and storage. For this reason we recommend that a thorough visual inspection is made immediately the unit is received. Should any damage be evident or any parts missing, ensure that Huntleigh or your distributor is informed at once.

Storage

Should the unit not be required for immediate use, it should be re-sealed into its original packing after carrying out the initial delivery inspection, and stored under covered conditions at a temperature between -10°C to $+40^{\circ}\text{C}$, and relative humidity of 10% to 93% non-condensing.

2.2 Battery Insertion / Replacement

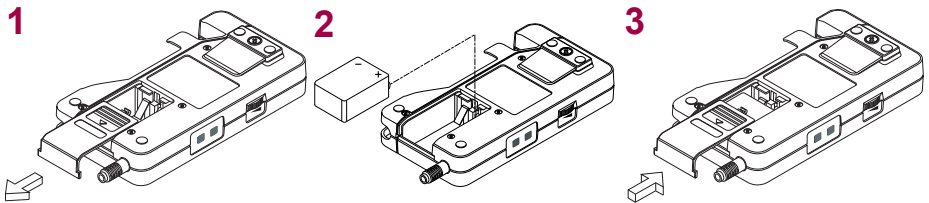

Note: Remove the battery if the unit is not likely to be used for some time.

2.3 Product Controls

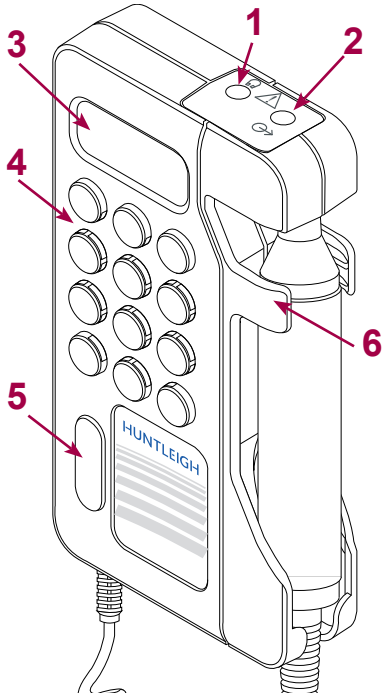



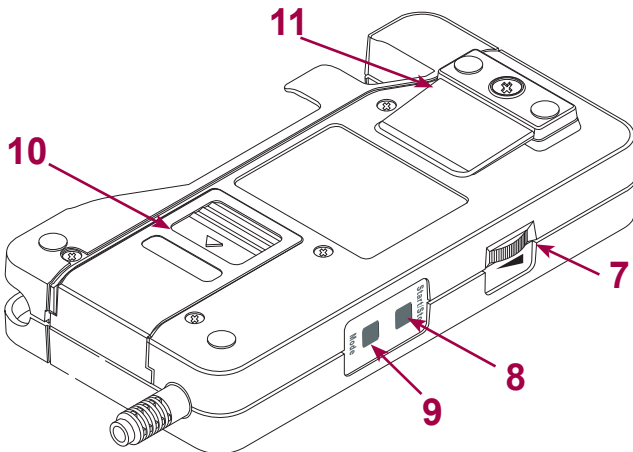



















	FD1 FD3	FD2	
1	•	•	Headphone Socket
2		•	RS232 Port
3	•	•	LCD Panel
4	•	•	Loud-speaker
5	•	•	On/Off Button
6	•	•	Probe Holder
7	•	•	Volume Control
8		•	Start/Stop Button
9		•	Mode Button
10	•	•	Battery Compartment
11	•	•	Pocket Clip



2.4 Product Labelling



Patient applied parts (ultrasound probes) are type BF according to the definitions in IEC 60601-1:2005.

	Attention, consult this manual.		
	Attention, consult accompanying documents / Instructions for Use		
	This symbol signifies that this product complies with the essential requirements of the Medical Device Directive (93/42/EEC) - Medical Device Regulation (EU/2017/745).		
Rx Only	Federal law restricts this device to sale by, or on the order of a licensed healthcare practitioner.		
IP20	Protected against ingress of solid foreign objects >12.5mm diameter. Not protected against ingress of water.		
Manufactured By:	Huntleigh Healthcare Ltd. 35 Portmanmoor Road, Cardiff, CF24 5HN, United Kingdom T: +44 (0)29 20485885 sales@huntleigh-diagnostics.co.uk www.huntleigh-diagnostics.com		
	Legal Manufacturer in association with the CE mark in Europe ArjoHuntleigh AB Hans Michelsensgatan 10 211 20 Malmö, Sweden		
	Power On/Off		Battery
	Temperature Limitations	"MAX 93% RH"	Limits of Relative Humidity
	Serial Number		Reference Number
	Medical Device		Device Identifier
	Fragile		Keep Dry
	Headphone Socket		Volume
	RS232 Interface		Alignment mark
	Cardboard packaging can be recycled.		Do not use hook
	PVC FREE Does not contain PVC		LATEX FREE Does not contain Latex
	Limits of Atmospheric Pressure		

3. Operation



Refer to diagram on inside front cover for Doppler Measuring sites and Recommended Probes.

To connect the probe, align the arrow on the connector with the slot on the probe and push firmly.

To disconnect the probe, pull the connector sharply. DO NOT pull the cable.

Note: During use, an automatic noise reduction feature operates on low level signals to improve sound quality.

Coupling Gel

Use water based ultrasound gel ONLY.

3.1 Vascular Mode (FD2 Only)

The FD2 will select vascular mode when a vascular probe is connected to the control unit.

Vascular Probes

Five probes are available for vascular examinations:

VP4HS	4MHz ±1% for deep lying vessels
VP5HS	5MHz ±1% for deep lying vessels and oedematous limbs
VP8HS	8MHz ±1% for peripheral vessels
VP10HS	10MHz ±1% for specialist superficial applications.
EZ8	8MHZ ±1% “Widebeam” for peripheral vessels.

In this mode, blood flow is audible in the loudspeaker. Probe frequency is displayed.

Clinical Use

Apply a liberal amount of gel on the site to be examined. Place the probe at 45° to the skin surface over the vessel to be examined. Adjust the position of the probe to obtain the loudest audio signal. High pitched pulsatile sounds are emitted from arteries while veins emit a non-pulsatile sound similar to a rushing wind.

For best results, keep the probe as still as possible once the optimum position has been found. Adjust the audio volume as required.

3.2 Obstetric Mode

Fetal Dopplex II (FD2)

Obstetric mode is automatically selected when an obstetric probe (OP2HS/OP3HS) is connected. Fetal Heart Rate (FHR) is displayed with 3 operating modes, and an RS232 interface provides for FHR printing when connected to the Dopplex Printa Package.

Obstetric Probes

Two probes are available for obstetric examinations:

OP2HS	2MHz ±1%
OP3HS	3MHz ±1%

Fetal Dopplex (FD1/FD3)

Operates in standard mode to provide FHR display. The probe/cable are waterproof and can be fully immersed for use in waterbirths.



The FD1/FD3 main unit is not waterproof and must not be immersed.

Clinical Use

Apply a liberal amount of gel to the abdomen*. Place the faceplate of the probe flat against the abdomen above the symphysis pubis. Adjust the probe to obtain an optimum audio signal ideally by angling the probe around. Avoid sliding it over the skin.

In early pregnancy a full bladder may improve sound detection. In later pregnancy the best signals are generally located higher on the abdomen. The fetal heart sounds like a galloping horse at approximately twice the maternal rate. A wind-like sound is heard from the placenta.

**Note: For FD1/FD3 : Gel is not required when probe is used underwater.*

Standard Mode - FD1/FD2/FD3



In this mode the FHR, averaged over 4-heart beats, is displayed on the 3-digit readout. The LCD displays an outline heart symbol.

Smoothed Mode - FD2 Only

This mode is used to obtain more stable heart rate readings. In this mode, FHR is averaged over 8 beats. The LCD displays a solid heart symbol.

Manual Mode - FD2 Only

This mode is used when a fetal heart beat is audible in the loudspeaker or headphones but, due to noise or a low signal level, the FD2 cannot reliably calculate the heart rate. In this mode, the heart rate can be manually counted over a period of 10 audible heart beats (see below). The FD2 will automatically calculate and display the derived FHR on the LCD. The LCD displays a clock symbol.

Mode Selection

Press the Mode button to select mode.

Use of Manual Mode (FD2 Only)

1. Press and hold Start/Stop button and immediately count the audible heart beats, counting the first beat as the button is pressed. The LCD displays the flashing clock symbol and the FHR reading is shown as three dashes.
2. Release the Start/Stop button immediately on the count of 10 (i.e. After nine beat intervals). The FD2 will automatically calculate the derived FHR averaged over the 10 beat period and display the result. This rate value is retained until the measurement is repeated or the unit is switched off. If the button is held for a period less than about 3 seconds the display will clear the previous rate value and reset.

Connection to Printa II™ (FD2 Only) 

Hard copy printing is automatically selected when the plug of the interface buffer box is inserted into the RS232 socket on the top panel of the FD2. Printing is then initiated by using the Start/Stop button.

3.3 After Use

1. Press and release the On/Off button. If you forget to switch the unit off, it will automatically shut-off after 3 minutes.
2. Refer to the cleaning section before storing or using the unit on another patient.
3. Store unit together with probe and accessories in the soft carry case provided.

4. Care and Cleaning

4.1 General Care

All Huntleigh products have been designed to withstand normal clinical use, however they can contain delicate components, for example the probe tip, which should be handled and treated with care.

Periodically, and whenever the integrity of the system is in doubt, carry out a check of all functions as described in the relevant section of the IFU. If there are any defects to the housing contact Huntleigh or your distributor for repair or to order a replacement.



Please ensure that you check with your facility's local infection control policy and medical equipment cleaning procedures.



Observe warnings and guidance on cleaning fluid labelling regarding use and personal protective equipment (PPE).



Do not use abrasive cloths or cleaners.



Do not use automatic washers or autoclaves.



Phenolic detergent based disinfectants, solutions containing cationic surfactants, ammonia based compounds or perfumes and antiseptic solutions such as Steriscol or Hibiscrub should never be used.



If detergent or disinfectant wipes are used ensure that excess solution is squeezed from the wipe prior to use.



Do not allow any fluid to enter the products and do not immerse in any solution.



Always wipe off disinfectant using a cloth dampened with clean water.

4.2 General Cleaning and Disinfecting

Always keep the external surfaces clean and free of dirt and fluids using a clean dry cloth.

1. Wipe any fluids from the surface of the product using a clean dry cloth.
2. Wipe with a cloth dampened in 70% Isopropyl Alcohol.
3. Completely dry with a clean, dry lint free cloth.
4. If the product has been contaminated use the methods described for patient applied parts.

4.3 Cleaning and Disinfecting Patient Applied Parts

Clean the probes before examining a patient using low risk cleaning method below.

Following patient examination, clean and/or disinfect the probes by the appropriate method based upon the level of cross contamination risk, as defined below:

Risk	Definitions	Procedure
Low	Normal use or low risk situations include patients having intact skin and no known infection.	<ol style="list-style-type: none"> 1. Remove soiling, wipe with a mild neutral detergent and then wipe with a cloth dampened in water. 2. Completely dry with a clean lint free cloth.
Medium	The patient has a known infection, skin is not intact, the part is heavily soiled, or the patient has given birth in a water bath.	<ol style="list-style-type: none"> 1. Follow low risk procedure then wipe with a cloth dampened in Sodium Hypochlorite (1,000ppm). 2. After two minutes wipe with a cloth dampened in water and then dry with a clean lint free cloth.
High	This procedure should only be used when the part has been contaminated by blood.	<ol style="list-style-type: none"> 1. Follow low risk procedure then wipe with a cloth dampened in Sodium Hypochlorite (10,000ppm). 2. After two minutes wipe with a cloth dampened in water and then dry with a clean lint free cloth.



Warning: Sodium Hypochlorite @ 10,000 ppm for disinfecting should only be used in situations described in the High Risk definition. Unnecessary use of this concentrated solution for Low and Medium risk situations may result in damage to the product. Do not allow Sodium Hypochlorite solutions to come into contact with metal parts.

The use of disinfectant materials other than those listed is the responsibility of the user for their efficacy and compatibility with the device.

4.4 Maintenance and Repair

Inspection is recommended each time the product is used, paying particular attention to the tip of the probes, checking for cracks etc., and to the cable and connector. Any crackling or intermittent behaviour should be investigated.



This product does not require periodic maintenance.

Suitable test equipment and a full range of spare parts are also available. Please refer to service manual for further information and part numbers.

A full technical description is provided in the Service Manual 726374.

5. Specifications

5.1 Equipment Classification

Type of protection against electric shock.	Internally powered equipment
Degree of protection against electric shock 	Type BF - equipment with an applied part. 
Mode of operation.	Continuous
Degree of protection against harmful ingress of particles and/or water.	Main Unit: IP20 FD1 / FD3 probes : IPX7 All other probes (Tip only): IPX1
Degree of safety of application in the presence of a flammable anaesthetic	Equipment not suitable for use in the presence of a FLAMMABLE ANAESTHETIC MIXTURE WITH AIR, OXYGEN OR NITROUS OXIDE

5.2 Standards Compliance



IEC60601-1: 1988 + A1:1991 +A2:1995
UL60601-1 : 2006
CSA C22.2 No 601.1-M90 (R2005)

5.3 FHR Performance*

Standard Mode	Range - 60-210bpm Averaging - 4 beats	Resolution - 1bpm Accuracy - ±3bpm
Smoothed Mode (FD2 only)	Range - 60-210bpm Averaging - 8 beats	Resolution - 1bpm Accuracy - ±3bpm
Manual Mode (FD2 only)	Range - 60-210bpm Averaging - 10 beats	Resolution - 1bpm Accuracy - ±3bpm

**(excluding user error)*

5.4 General

Max. Audio Output (Loudspeaker)	500mW rms typical
Auto shut-off	3 minute no signal 10 minute unconditional
Headphones 	Max. output Power: 25 mW rms (32Ω) Connector: 3.5mm stereo jack socket Max. applied voltage: +9Vdc
RS232 Interface (FD2 only) 	Data format: RS232C Connector: 8pin subminiature DIN socket Max. applied voltage: +5Vdc
Battery Type	IEC 6LR61 or IEC 6LP3146
Battery Life	Typically, 250 x 1 minute examinations
Size	Height 140mm, Depth 27mm, Width 74mm
Weight	295g

5.5 Environmental

Operating		Storage
+10°C to +30°C	Temperature range	-10°C to +40°C
10% to 90% (non condensing)	Relative Humidity	93% maximum
860mb to 1060mb	Pressure	860mb to 1060mb

6. End of Life Disposal

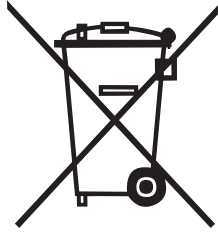

This symbol signifies that this product, including its accessories and consumables is subject to the WEEE (Waste Electrical and Electronic Equipment) regulations and should be disposed of responsibly in accordance with local procedures.

7. Warranty & Service

Huntleigh Healthcare Ltd. standard terms and conditions apply to all sales. A copy is available on request. These contain full details of warranty terms and do not limit the statutory rights of the consumer.

Service Returns

If for any reason Dopplex unit has to be returned, please:

- Clean the product following the instructions in this manual.
- Pack it in suitable packing.
- Attach a decontamination certificate (or other statement declaring that the product has been cleaned) to the outside of the package.
- Mark the package 'Service Department - FD1 / FD2 / FD3'

For further details, refer to NHS document HSG(93)26 (UK only).

Huntleigh Healthcare Ltd reserve the right to return product that does not contain a decontamination certificate.

For service, maintenance and any questions regarding this, or any other Huntleigh Healthcare Dopplex product, please contact:

Customer Care Department.
Huntleigh Healthcare, Diagnostic Products Division,
35, Portmanmoor Rd.,
Cardiff. CF24 5HN
United Kingdom.

Tel: +44 (0)29 20496793 - Service (24hr answer machine)
Tel: +44 (0)29 20485885
Fax: +44 (0)29 20492520
Email: sales@huntleigh-diagnostics.co.uk
service@huntleigh-diagnostics.co.uk
www.huntleigh-diagnostics.com

If a serious incident occurs in relation to this medical device, affecting the user, or the patient then the user or patient should report the serious incident to the medical device manufacturer or the distributor.
In the European Union, the user should also report the serious incident to the Competent Authority in the member state where they are located.

Manufactured in the UK by Huntleigh Healthcare Ltd on behalf of;



ArjoHuntleigh AB
Hans Michelsensgatan 10
211 20 Malmö, Sweden



Huntleigh Healthcare Ltd.

35 Portmanmoor Road, Cardiff, CF24 5HN, United Kingdom
T: +44 (0)29 20485885 sales@huntleigh-diagnostics.co.uk
www.huntleigh-diagnostics.com

Registered No: 942245 England & Wales. Registered Office:
ArjoHuntleigh House, Houghton Hall Business Park, Houghton Regis, Bedfordshire, LU5 5XF
©Huntleigh Healthcare Limited 2004-2014

A Member of the Arjo Family

® and ™ are trademarks of Huntleigh Technology Limited

As our policy is one of continuous improvement, we reserve the right to modify designs without prior notice.

HUNTLEIGH

726332EN-11
(ENGLISH)

03/2021