

INSTRUCTIONS FOR USE

D920^{MKIII} & D930^{MKIII}

Handheld Dopplers



Contents

1. Introduction	3
1.1 Unpacking / Preliminary Checks	3
2. Safety	3
2.1 Warnings	3
2.2 Patient Applied Parts	3
2.3 Intended Use & Indications	3
2.4 Contraindications	3
2.5 Patient Population	4
3. Warranty and Service	4
3.1 Service Life	4
3.2 Maintenance and Repair	4
4. Product Identification	5
4.1 Product Controls	5
4.2 Symbol Identification	6
5. Prepare the Doppler for Use	7
5.1 Battery Insertion / Replacement	7
6. Operation	7
6.1 Battery Saver	7
6.2 After Use	7
7. Care and Cleaning	8
7.1 General Care	8
7.2 Cleaning and Disinfecting the Doppler	8
7.3 Cleaning and Disinfecting Probes	8
8. Specifications	9
8.1 Equipment Classification	9
8.2 General	9
8.3 Environmental	9
8.4 Standards Compliance	9
8.5 Accessories	9
9. Electromagnetic Compatibility	10

1. Introduction

The D920 & D930 are battery powered, hand-held Dopplers for obstetric use. They provide an audible fetal heart sound. This equipment is for use only by suitably qualified healthcare practitioners and is not intended for use by the patient.

Before using this equipment, study this manual carefully and familiarise yourself with the controls, display features and operation.

Experience with use of ultrasonic dopplers is preferable, but for novice users training material is provided with the online documents. Exposure to ultrasound should be kept As Low As Reasonably Achievable - (ALARA guidelines).

Scan the QR code on the rear cover of this IFU with a smartphone, or visit the Huntleigh website for electronic copies of user literature. All documents are available to download as PDF files. To read them, you must have a PDF reader installed on your device. Alternatively paper copies are available upon request.

1.1 Unpacking / Preliminary Checks

On receipt of your Doppler, check that all items are present and undamaged. If items are missing or have been damaged in transit, inform Huntleigh Healthcare immediately.

Handheld Doppler	IFU (this document)	Batteries
Ultrasound Gel	Carry bag	

2. Safety

2.1 Warnings

- Dopplers are screening tools to aid the healthcare professional. If there is doubt as to fetal status, further investigations should be undertaken immediately using alternative techniques.
- Always ensure that Maternal HR or any Artefacts are not misinterpreted as fetal heartrate. If in doubt, feel the mother's pulse during the examination.
- Do not use in the presence of flammable gases.
- Do not use in a sterile field unless additional barrier precautions are taken.
- Do not sterilise the product or its accessories. The product will be damaged.
- Do not expose to excessive heat, including prolonged exposure to sunlight.
- Do not dispose of batteries in fire as this can cause them to explode.
- The Doppler is not waterproof and must not be immersed.
- This product contains sensitive electronics, which are susceptible to interference, this will be indicated by unusual sounds.
- This equipment must not be modified.

2.2 Patient Applied Parts

As defined in IEC 60601-1 the patient applied parts of the Dopplers are the ultrasound probes.

2.3 Intended Use & Indications

The Dopplers are intended for use by qualified healthcare practitioners in primary, acute and community healthcare environments, for the assessment of fetal heart rate..

They are indicated for routine screening of pregnant women of all ages from early gestation through to full term, and for low risk labour management.

2.4 Contraindications

- Do not use on broken or fragile skin.
- Do not use on the eye.

2.5 Patient Population

The D920 and D930 are suitable for use on all patient populations.

3. Warranty and Service

Huntleigh Healthcare Diagnostic Products Division standard terms and conditions apply to all sales. A copy is available on request. These contain full details of warranty terms and do not limit the statutory rights of the consumer.

Service Returns: To return the Doppler:

- Clean the product following the instructions in this manual.
- Pack it in suitable packing.
- Attach a decontamination certificate (or other statement declaring that the product has been cleaned) to the outside of the package. (Huntleigh Healthcare Ltd reserve the right to return product that does not contain a decontamination certificate).
- Call Huntleigh in Addison, IL for a return authorization number.

Service Department
ArjoHuntleigh Inc.
2349 West Lake Street,
Addison,
IL 60101, USA

T: 1-800-323-1245 option 2

W: www.ArjoHuntleigh.com

3.1 Service Life

This is defined as the period during which the device is expected to remain safe and suitable to meet its intended use, and all risk control measures remain effective.

The service life for this device is seven years.

3.2 Maintenance and Repair

There are no user serviceable parts inside the Doppler unit or probes. This product does not require periodic maintenance. Inspection is recommended each time the product is used, paying particular attention to the tip of the probes, checking for cracks etc., and to the cable. Any unusual sounds or intermittent behaviour should be investigated.

Spare parts are available. Please refer to service manual for further information and part numbers. A full technical description is provided in the Service Manual 793329.

Caution

Servicing cannot be carried out while the Doppler is in use.

4. Product Identification



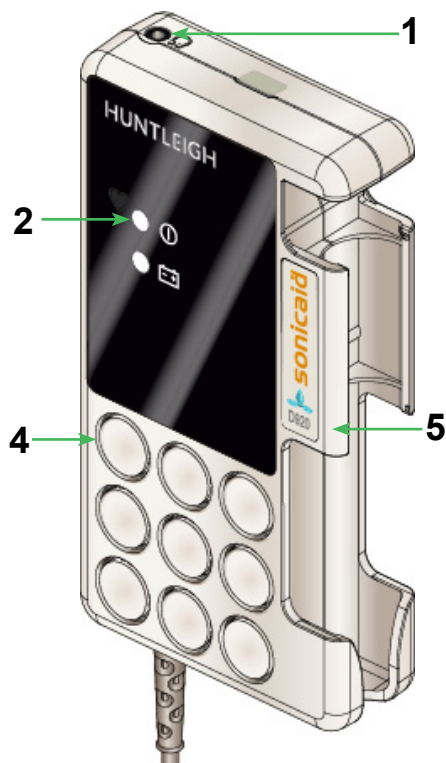



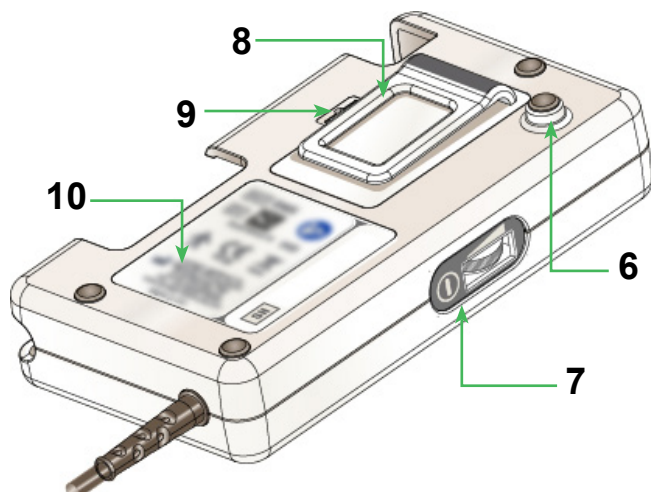















4.1 Product Controls



1	Headphone Socket
2	Green LED: indicates power ON
3	Yellow LED: flashes when batteries are low
4	Loudspeaker
5	Probe Holder
6	Trolley Mount
7	On/Off/Volume
8	Pocket Clip
9	Battery Compartment
10	Rear Panel Label



4.2 Symbol Identification

	Patient applied parts (ultrasound probes) are type BF according to the definitions in IEC 60601-1.		
	General Warning		Attention, consult accompanying documents / Instructions for Use
	This symbol signifies that this product, including its accessories and consumables is subject to the WEEE (Waste Electrical and Electronic Equipment) regulations and should be disposed of responsibly in accordance with local procedures.		
	This symbol signifies that this product complies with the essential requirements of the Medical Device Directive (93/42/EEC) - Medical Device Regulation (EU/2017/745).		
RxOnly	Federal law restricts this device to sale by, or on the order of a licensed healthcare practitioner.		
Made in in the UK by:	Huntleigh Healthcare Ltd. 35 Portmanmoor Road, Cardiff, CF24 5HN, United Kingdom T: +44 (0)29 20485885 sales@huntleigh-diagnostics.co.uk www.huntleigh-diagnostics.com		
	Legal Manufacturer in association with the CE mark in Europe ArjoHuntleigh AB Hans Michelsensgatan 10 211 20 Malmö, Sweden		
IP20	Protected against ingress of solid foreign objects >12.5 mm diameter. Not protected against ingress of water.		
IPx7	Protected against ingress of water 1 m immersion for up to 30 minutes.		
	Power On/Off		Battery
	Device Identifier		Serial Number
	Reference Number		Medical Device
	Fragile		Keep Dry
	Atmospheric Pressure Limitations		Relative Humidity Limitations
	Temperature Limitations		Cardboard packaging can be recycled
	LATEX FREE Does not contain Latex		PVC FREE Does not contain PVC
	Headphone Socket		Volume

Note: Product labelling should be readable from a distance of up to 0.7m.

5. Prepare the Doppler for Use

5.1 Battery Insertion / Replacement

Disconnect the Doppler from other equipment before removing the battery cover.



Insert a suitable tool into the recess, release the clip and gently lever off the battery cover.

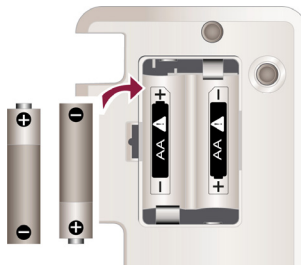

Insert the batteries according to the diagram, observing polarity.

- Use only alkaline LR6 (AA) non-rechargeable batteries.

Note: *If the Doppler will not be used for an extended period, remove the batteries.*

Low Battery Indication

The yellow LED flashes when the batteries are low. The batteries should then be replaced for reliable operation.

6. Operation

Turn the On/Off/Volume control to the On position. The green LED indicates power On.

Note: *D920 is fitted with a 2 MHz probe while D930 is fitted with a 3 MHz probe. The probes and cables are waterproof but do NOT immerse the Doppler hand unit.*

Clinical Use

Make the patient comfortable in a semi-recumbant or sitting position. Apply a liberal amount of gel to the abdomen. Place the faceplate of the probe flat against the abdomen above the symphysis pubis. Adjust the probe to get an optimum audio signal, ideally by angling the probe around while maintaining firm pressure. Avoid sliding the probe over the skin. Best performance is from the fetal heart itself, characterised by 'slapping' valve sounds rather than umbilical artery or placental sounds.

6.1 Battery Saver

To prolong battery life, the Doppler will automatically go to sleep after three minutes of no signal or ten minutes of use. To wake the Doppler, turn the On/Off/Volume control to the Off position, then On again.

6.2 After Use

Turn the On/Off/Volume control to the Off position.

Refer to the cleaning section before storing or using the unit on another patient.

7. Care and Cleaning

7.1 General Care

The Doppler contains delicate components, particularly the probe tip, which should be handled and treated with care. Periodically, and whenever the integrity of the system is in doubt, carry out a check of all functions as described in this IFU. If there are any defects, contact Huntleigh or your distributor for repair or to order a replacement.

Caution

- Check with your facility's local infection control policy and medical equipment cleaning procedures.
- Observe warnings and guidance on cleaning fluid labelling regarding use and personal protective equipment (PPE).
- If detergent or disinfectant wipes are used, make sure that excess solution is squeezed from the wipe prior to use.
- Always switch off the Doppler before cleaning and disinfecting.
- Always wipe off disinfectant using a cloth dampened with clean water.
- Do not allow any fluid to enter the products and do not immerse in any solution.
- Do not use abrasive cloths or cleaners.
- Do not use automatic washers or autoclaves.
- Do not use Phenolic detergent based disinfectants, solutions containing cationic surfactants, ammonia based compounds or perfumes and antiseptic solutions.

7.2 Cleaning and Disinfecting the Doppler

Always keep the external surfaces clean and free of dirt and fluids using a clean dry cloth.

- Wipe any fluids from the surface of the product using a clean dry cloth.
- Wipe with a cloth dampened in 70% Isopropyl Alcohol.
- Completely dry with a clean, dry cloth.
- If the product has been contaminated use the methods described for probes

7.3 Cleaning and Disinfecting Probes

Clean the probes before examining a patient using the low risk cleaning method below. Following patient examination, clean and/or disinfect the probes by the appropriate method based upon the level of cross contamination risk, as defined below:

Risk	Definitions	Procedure
Low	Normal use or low risk situations include patients having intact skin and no known infection.	1. Remove soiling, wipe with a mild neutral detergent and then wipe with a cloth dampened in water. 2. Completely dry with a clean cloth.
Medium	The patient has a known infection, skin is not intact, the part is heavily soiled.	1. Follow low risk procedure then wipe with a cloth dampened in Sodium Hypochlorite (1,000ppm). 2. After two minutes wipe with a cloth dampened in water and then dry with a clean cloth.
High	This procedure should only be used when the part has been contaminated by blood.	1. Follow low risk procedure then wipe with a cloth dampened in Sodium Hypochlorite (10,000ppm). 2. After two minutes wipe with a cloth dampened in water and then dry with a clean cloth.



Caution

Repeated and unnecessary use of concentrated solutions will result in damage to the product. Do not allow Sodium Hypochlorite solutions to come into contact with metal parts.

The use of disinfectant materials other than those listed is the responsibility of the user for their efficacy and compatibility with the device.

8. Specifications

8.1 Equipment Classification

Type of protection against electric shock	Internally powered equipment
Degree of protection against electric shock 	Type BF - equipment with an applied part 
Mode of operation.	Continuous
Degree of protection against harmful ingress of particles and/or water.	Main Unit: IP20*, Probes : IPX1
Degree of safety of application in the presence of a flammable anaesthetic	Equipment not suitable for use in the presence of a FLAMMABLE ANAESTHETIC MIXTURE WITH AIR, OXYGEN OR NITROUS OXIDE

*For home use, this can be upgraded to IPX2 when using the protective pouch (ACC-OBS-080).

8.2 General

Max. Audio Output	500mW rms typical (loudspeaker)		
Auto shut-off	After five minutes of continuous operation		
Headphone output	Max. output Power: 25 mW rms (32Ω) Connector: 3.5 mm stereo jack socket		
Battery Type and Life	LR6 (AA) Alkaline cells, 2 x 1.5 V, Typically 500 one minute examinations		
Size	140 x 33 x 75 mm	Weight	267 g

8.3 Environmental

Operating	
Temperature range	+5°C to +40°C
Relative Humidity	15% to 90% (non condensing)
Pressure	700 hPa to 1060 hPa
Transport and Storage between uses	
Without relative humidity control	-25°C to +5°C
At a r.h. of up to 90% non-condensing	+5°C to +35°C
At a water vapour pressure up to 50 hPa	>+35°C to +70°C

8.4 Standards Compliance

UL60601-1 : 2006	CSA C22.2 No 601.1-M90 (R2005)
IEC 60601-1: 2020	IEC 60601-1-11: 2015
IEC 60601-2-37: 2015 Thermal Indices (TI) and Mechanical Index (MI) are below 1.0 for all device settings.	IEC 60601-1-2: 2014

8.5 Accessories

Use only the recommended accessories. See www.huntleigh-diagnostics.com for a list of accessories.

9. Electromagnetic Compatibility

Make sure the environment in which the Doppler is installed is not subject to strong sources of electromagnetic interference (e.g. radio transmitters, mobile phones). This equipment generates and uses radio frequency energy. If not installed and used properly, in strict accordance with the manufacturer's instructions, it may cause or be subject to interference. Type-tested in a fully configured system, complies with IEC 60601-1-2, the standard intended to provide reasonable protection against such interference. Whether the equipment causes interference may be determined by turning the equipment off and on. If it does cause or is affected by interference, one or more of the following measures may correct the interference:

- Reorient the equipment
- Relocate the equipment with respect to the source of interference
- Move the equipment away from the device with which it is interfering

Warnings

- **The use of accessories, transducers and cables other than those specified, with the exception of transducers and cables sold by the manufacturer of the Doppler as replacement parts for internal components, may result in increased emissions or decreased immunity of the Doppler.**
- **The Doppler should not be used adjacent to or stacked with other equipment and that if adjacent or stacked use is necessary, the Doppler should be observed to verify normal operation in the configuration in which it will be used.**
- **Portable RF communications equipment (including peripherals such as antenna cables and external antennas) should be used no closer than 30 cm (12 inches) to any part of the Doppler including cables specified by the manufacturer. Otherwise, degradation of the performance of this equipment could result.**

As a proud member of the Arjo family, we have been committed to supporting healthcare professionals in improving outcomes and enhancing patient wellbeing since 1979. We do this through our proven solutions for Vascular Assessment & Treatment and Fetal & Patient Monitoring. With innovation and customer satisfaction as our guiding principles, we strive for clinical excellence and improved performance, for life.

Distributed in the USA by:

Arjo Inc..

2349 West Lake Street, Suite 250 Addison, Illinois 60101

T: +1 (800) 323 1245 F: +1 888 594 2756

www.huntleigh-healthcare.us

Registered No: 942245 England & Wales. Registered Office:

ArjoHuntleigh House, Houghton Hall Business Park, Houghton Regis, Bedfordshire, LU5 5XF

©Huntleigh Healthcare Limited 2015-2020

A Member of the Arjo Family

As our policy is one of continuous improvement, we reserve the right to modify designs without prior notice.

AW:1001047-4

HUNTLEIGH